

1-chip stabiliser

Written by Hans Summers
Friday, 04 September 2009 22:13 -

Here's a 1-chip stabiliser! Yes, it really is possible to make a Huff Puff stabiliser using a single 74HC4060! This ultra-simple design doesn't include the VFO of course. For development purposes, I re-used the same 74HC74 VFO of the 2- and 3-chip projects, but opened the Huff Puff correction loop such that it was unstabilised.

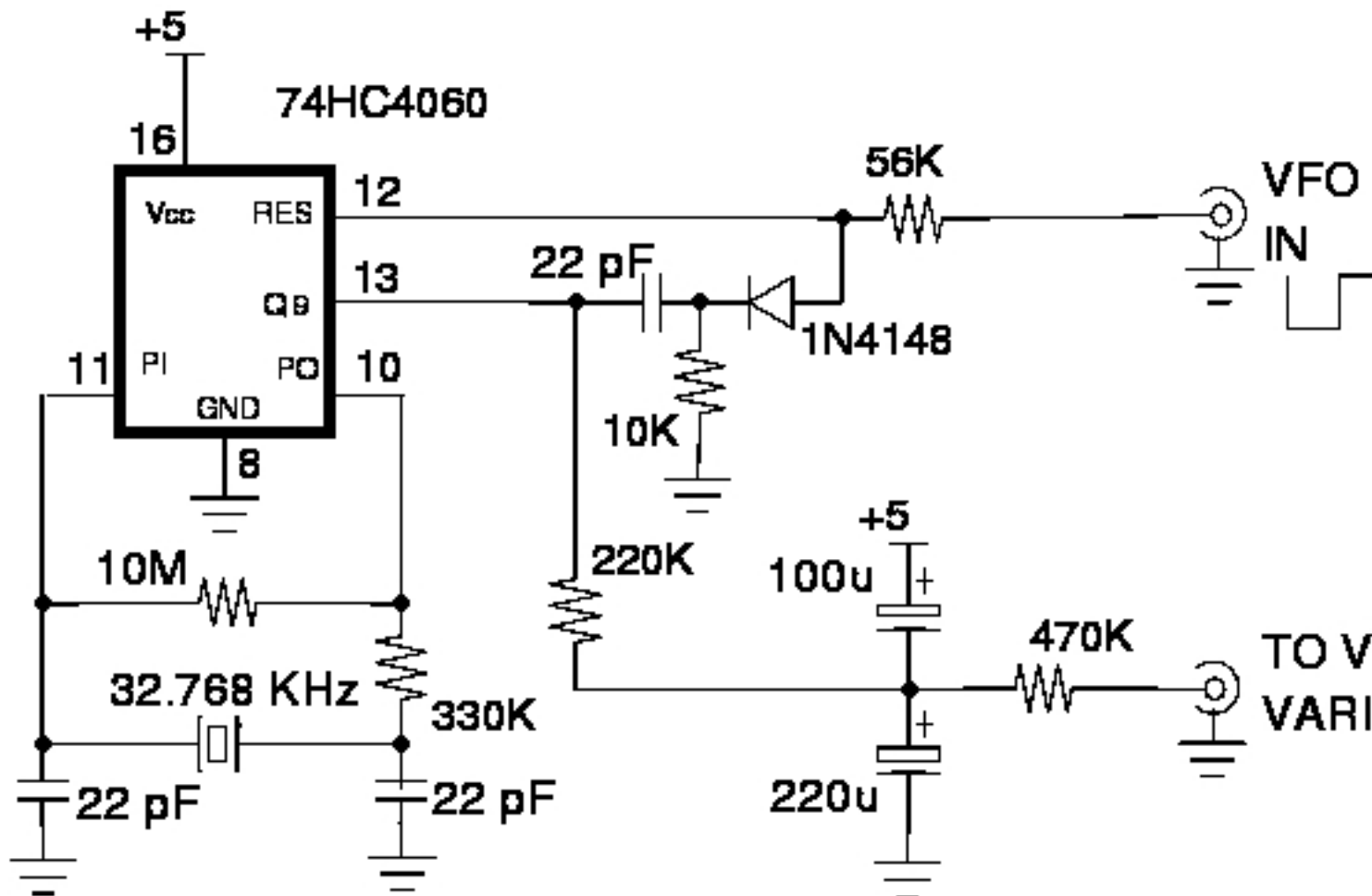

1-chip stabiliser

Written by Hans Summers
Friday, 04 September 2009 22:13 -

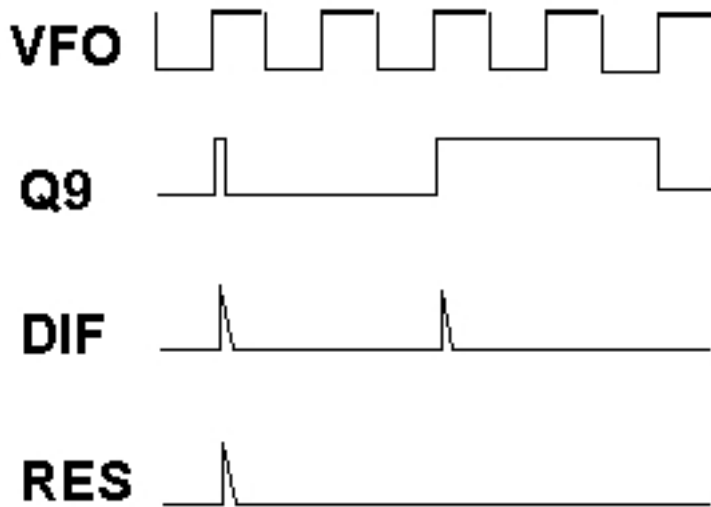

1-Chip Huff & Puff Stabiliser Hans Summers, 2004

